

WALL IRONERS

R-18/100

R-18/120

FEATURES

These machines are small in dimensions and mural, so they can be placed in a reduced space, with hardly installation as they do not have air exhaust or connections except the electric supply.



- Front feed and return.
- Panels in skinplate (top panel in stainless steel).
- Roll dimensions from 1 m to 1,20 m wide and 180 mm diameter.
- Electronic microprocessor:
 - Start / Stop,
 - Selection 4 temperatures.
- Electric heating.
- **Standard model:** roll covered in polyester and cotton felt.
- **NOMEX model:** padded and covered in Nomex, to work at higher temperature, up to 190°C.
- Chest in anodized aluminium.
- Manuel lifting of the chest by pedal.

OPTIONS

- Special voltages

TECHNICAL DATA	UNIT.	R-18/100	R-18/120
TECHNICAL DATA			
Theoretical production 20-25 % humidity	Kg/h	15	20
Ø Roll	mm	180	180
Working width	mm	1.000	1.200
Working speed	mt/min	2,02	2,02
Electronic Control	-	Yes	Yes
Bed lifting	-	Manual	Manual
POWER			
Heating Power	Kw	3,3	4
Roller Motor Power	Kw	0,03	0,03
Total electric Power	Kw	3,33	4,03
Tension	V	230V 50/60 Hz	230V 50/60 Hz
DIMENSIONS			
Width	mm	1.286	1.486
Depth	mm	430	430
Height	mm	970	970
Weight	Kg	88	90
Volume	m3	0,54	0,62
PACKING DIMENSIONS			
Width	mm	1.490	1.690
Depth	mm	540	540
Height	mm	1.140	1.140
Weight	Kg	104	108
Volume	m3	0,74	0,85
OTHERS			
Sound Level	dB	45	45

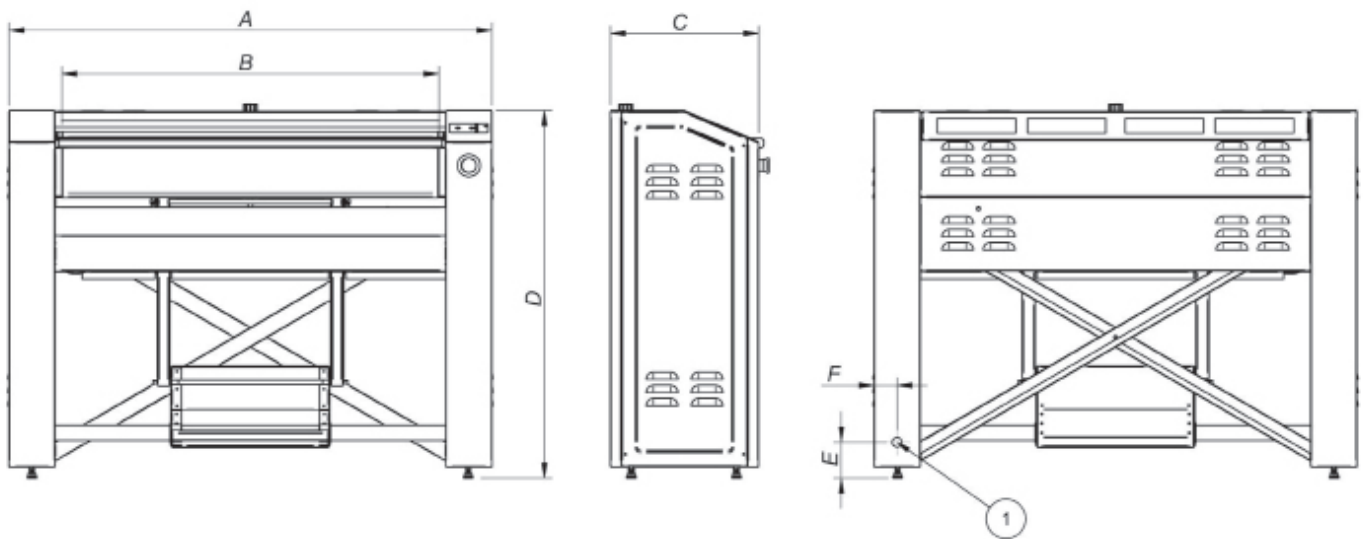

01. Electrical connection.

	A	B	C	D	E	F
R-18/100	1.286	1.000	400	970	95	61
R-18/120	1.486	1.200	400	970	95	61