

UTILITY FORM FINISHER FOR COATS, JACKETS AND DRESSES

MF
MF-C



- The working cycle is completely automatic and the steaming and drying duration is adjustable by three timers
- The shoulder width and the bag are adjustable
- The support of the bag (frame) with its controls rotates to 360°

MF (WITHOUT BOILER)

- Without steam boiler, to be connected to a central steam supply
- It needs a steam inlet and outlet
- Can be installed with steam generator GV-24 - 15 kw

MF-C (SELF-CONTAINED)

- Complete with built-in steam boiler, 18 litres, with automatic water feeding and automatic pressure control (4,5 bar)
- Voltage 400 V III +N / 230 V III 50-60 Hz



TECHNICAL DATA	UNIT.	MF-C WITH BOILER	MF WITHOUT BOILER
GENERAL DETAILS			
Board dimensions	mm	-	-
Boiler	-	Yes	No
Boiler capacity	l	18	-
Compressor	-	-	-
Group of Iron	-	-	-
Steam gun	-	Opt	-
Polished upper buck	-	-	-
POWER			
Vacuum Motor	HP	-	-
Pump Motor	HP	0,8	-
Boiler Heater (Mod. with option)	kW	12	-
Fan motor	kW	1	1
CONNECTIONS			
Ø Water inlet	BSP	3/8"	-
Ø Boiler exhaust (mod. with boiler)	BSP	1/2"	-
Ø Steam inlet	BSP	-	3/8"
Ø Condensate outlet	BSP	-	3/8"
Steam pressure	BAR	4,5	4,5
Steam Consumption	Kg/h	10-15	10-15
Ø Air inlet	BSP	-	-
Ø Air outlet	mm	-	-
Ø Air pressure	BSP	-	-
Ø Air Consumption	BAR NI/m	-	-
DIMENSIONS / PACKING DIMENSIONS			
Width / Width	mm	1.360 / 1.390	1.200 / 1.390
Depth / Depth	mm	610 / 640	580 / 640
Height / Height	mm	1.780 / 1.910	1.620 / 1.910
Net weight / Gross weight	kg	130 / 151	88 / 109
Volume	m ³	1,48 / 1,70	1,13 / 1,70
OTHERS			
Voltage	Hz	230/400V III 50-60	230/400V III 50-60
Sound level	dB	70	70

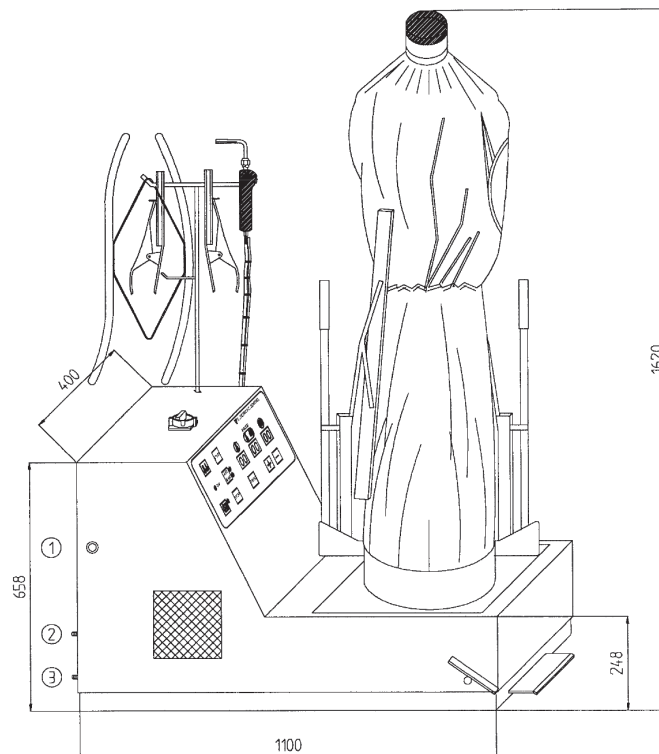

01. Electrical connection
02. Condensate
03. Steam inlet