

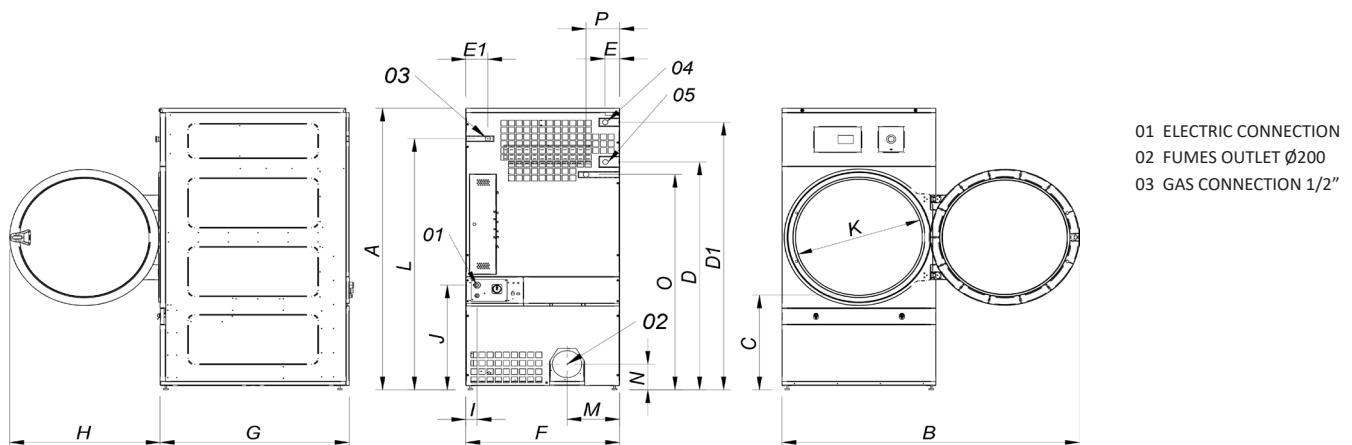

TECHNICAL DATA	UNIT.	DD-23 BASIC EM	DD-28 BASIC EM	DD-35 BASIC EM			
<b>CAPACITY</b>							
Capacity 1/18	Kg	26	31	37			
Capacity 1/20	Kg	23	28	33			
Hourly Output BASIC*	Kg/h	35-33	56-53	70-65			
Evaporation capacity BASIC*	l/h	16,30	30,90	32,10			
<b>DRUM</b>							
Ø Drum	mm	750	947	947			
Ø Door	mm	574	802	802			
Door center height	mm	976	1.040	1.040			
Load hole bottom height	mm	689	640	640			
Drum length	mm	746	780	936			
Drum volume	l	330	550	660			
<b>POWER</b>							
Drum motor power	Kw	0,37	0,55	0,55			
Fan motor power BASIC	Kw	0,25	0,55	0,55			
Electric heating power ALL RANGES	Kw	18	30	36			
Total electric power (elec.model) BASIC	Kw	18,67	31,15	37,15			
Gas heating power ALL RANGES	Kw	20,51	41	41			
Total electric power (gas model) BASIC	Kw	0,67	1,15	1,15			
Gas heating power ALL RANGES	Kw	-	-	-			
Elect. heating power (gas model) BASIC	Kw	-	-	-			
<b>CONNECTIONS</b>		<b>ELECTRICAL</b>	<b>GAS</b>	<b>ELECTRICAL</b>	<b>GAS</b>	<b>ELECTRICAL</b>	<b>GAS</b>
Tension 230V - I + N + T	N° x mm2 / A	-	3 x 1,5 / 20A	-	3 x 1,5 / 20A	-	3 x 1,5 / 20A
Tension 230V - III + T	N° x mm2 / A	4 x 16 / 63A	3 x 1,5 / 20A	4 x 35 / 100A	3 x 1,5 / 20A	4 x 50 / 125A	3 x 1,5 / 20A
Tension 400V - III + N + T	N° x mm2 / A	5 x 10 / 32A	3 x 1,5 / 20A	5 x 16 / 63A	3 x 1,5 / 20A	5 x 16 / 63A	3 x 1,5 / 20A
Ø Gas inlet	BSP	1/2"		1/2"		1/2"	
<b>DIMENSIONS / PACKING DIMENSIONS</b>							
Net width / Gross width	mm	890 / 970		985 / 1.065		985 / 1.065	
Net Depth / Gross Depth	mm	1.255 / 1.345		1.054 / 1.154		1.210 / 1.310	
Net Height / Gross Height	mm	1.812 / 1.940		1.946 / 2.080		1.946 / 2.080	
Height without heating battery	mm	-		-		-	
Net weight / Gross weight	Kg	210 / 230		230 / 260		260 / 285	
<b>OTHERS</b>							
Max airflow BASIC	m3/h	850		1.200		1.200	
Ø Fume exhaust	mm	200		200		200	
Sound level BASIC	dB	65		65		65	

\* It may vary depending on the type of heating, filter cleanliness or extraction type.



	A	B	C	D	D1	E	E1	F	G	H	I	J	K	L	M	N	O	P
DD-23	1812	1552	742	1430	1532	112	55	890	1255	735	95	920	575	1344	238	180	885	65
DD-28	1946	1910	660	1590	1875	102	130	985	1054	970	70	730	802	1760	337	178	1510	215
DD-35	1946	1910	660	1590	1875	102	130	985	1210	970	70	730	802	1760	337	178	1510	215