



DD-GOLD ET2

TUMBLE

DRYERS

DD-45 / 60 / 80



EASY TOUCH 2

7" touch screen user friendly and programmable ET2 USB Connection. PC software free of charge for programming, traceability, data analysis... Videos on display (ads, instructions, etc.) 37 languages



OUTSTANDING FEATURES

Reversing drum action as standard
Stainless steel drum as standard
Frequency inverter as standard



EFFICIENCY

CARE DRY - Intelligent humidity control. With new drum inlet temperature control
AIR RE-CYCLE - Efficient air recirculation system
INSULATED PANELS - Complete air-flow circuit
Double door glass
OPTIMAL FLOW - New 'optimized' system of mixed airflow
Big fluff filter



VERSATILITY

Make to order - customisation
WET CLEANING



CONNECTIVITY

Remote technical service
Management of laundries



ERGONOMICS

Drawer as fluff filter, made of stainless steel
Biggest door diameters



MAINTENANCE

Technical menu: statistics, alarm, autotest, data recovery for technicians and maintenance



OTHERS

Grey skinplate outer casing, stainless steel look
SPRINKLER - Integrated Fire Extinguishing System
SOFT DRY - new drum with stamped holes
COOL DOWN - anti-wrinkle at the end of the cycle
Electric, gas and steam heating
CE approved



OPTIONS

- New perfumes dosing/vaporizing system
- Printer
- Danube Online communication kit
- Tropicalized model
- Rear panel with external air inlet + filter
- Stainless steel outer casing
- Stainless steel front panel
- Stainless steel battery
- Low pressure steam battery
- Reverse door opening
- Fluff filter with grid 0,6 or 1,2 mm (standard is 0,3 mm)



Intertek



Intertek

TECHNICAL DATA	UNIT.	DD-45 GOLD ET2	DD-60 GOLD ET2	DD-80 GOLD ET2			
CAPACITY							
Capacity 1/18	Kg	50	67	83			
Capacity 1/20	Kg	45	60	75			
Hourly Output GOLD*	Kg/h	108-96	144-129	192-171			
Evaporation capacity GOLD*	l/h	48,2	72	93,8			
DRUM							
Ø Drum	mm	1.225	1.225	1.225			
Ø Door	mm	802	802	802			
Door center height	mm	1.275	1.275	1.275			
Load hole bottom height	mm	874	874	874			
Drum length	mm	760	1.020	1.252			
Drum volume	l	896	1.202	1.500			
POWER							
Drum motor power	Kw	0,75	1,1	1,5			
Fan motor power GOLD	Kw	2,2	2,2	2,2			
Electric heating power ALL RANGES	Kw	54	72	72			
Total electric power (elec.model) GOLD	Kw	57	75,35	75,75			
Gas heating power ALL RANGES	Kw	60	90	120			
Total electric power (gas model) GOLD	Kw	3	3,35	3,75			
Steam heating power ALL RANGES	Kw	91,3	128	128			
Total electric power (steam model) GOLD	Kw	3	3,35	3,75			
CONNECTIONS							
		ELECTRICAL	STEAM / GAS	ELECTRICAL	STEAM / GAS	ELECTRICAL	STEAM / GAS
Tension 230V - I + N + T	Nº x mm2 / A	-	-	-	-	-	-
Tension 230V - III + T	Nº x mm2 / A	-	4 x 2,5 / 20A	-	4 x 2,5 / 32A	-	4 x 2,5 / 32A
Tension 400V - III + N + T	Nº x mm2 / A	5 x 35 / 100A	5 x 1,5 / 20A	5 x 50 / 125A	5 x 1,5 / 32A	5 x 50 / 125A	5 x 1,5 / 32A
Ø Gas inlet	BSP	3/4"		3/4"		3/4"	
Ø Steam inlet	BSP	1"		1"		1"	
Ø Condensed (Steam models)	BSP	1"		1"		1"	
DIMENSIONS / PACKING DIMENSIONS							
Net Width / Gross Width	mm	1.270 / 1.330		1.270 / 1.330		1.270 / 1.330	
Net Depth / Gross Depth	mm	1.106 / 1.185		1.366 / 1.445		1.598 / 1.705	
Net Height / Gross Height	mm	2.380 / 2.150		2.380 / 2.150		2.380 / 2.150	
Height without heating battery	mm	1.950		1.950		1.950	
Net weight / Gross weight	Kg	395 / 430		529 / 575		657 / 715	
OTHERS							
Max airflow GOLD	m3/h	4500		4500		4500	
Ø Fume exhaust	mm	300		300		300	
Sound level GOLD	dB	67		67		67	

* It may vary depending on the type of heating, filter cleanliness or extraction type.

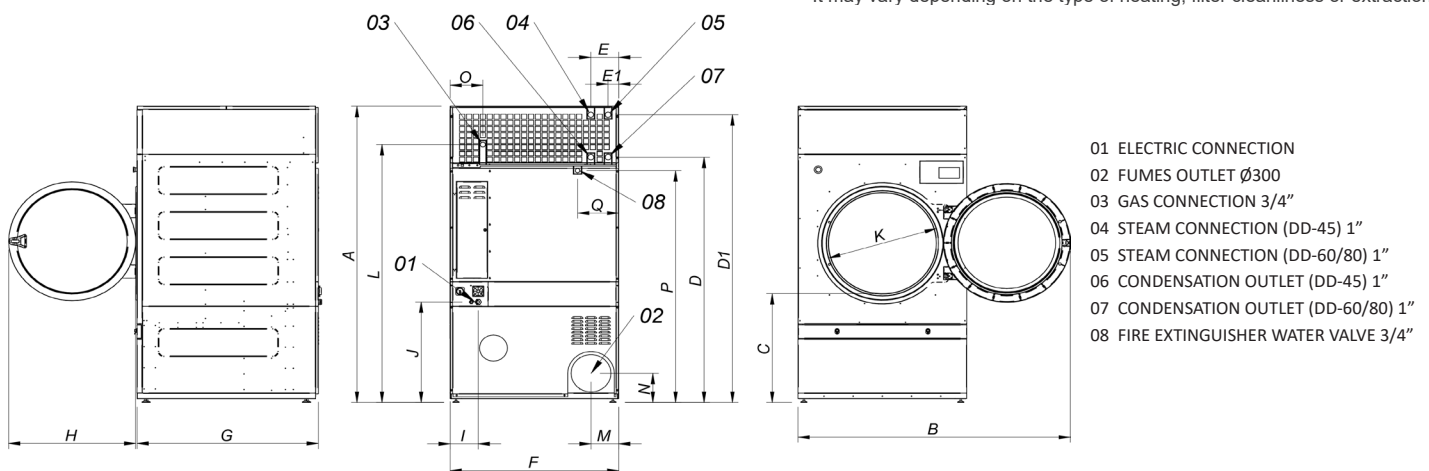

	A	B	C	D	D1	E	E1	F	G	H	I	J	K	L	M	N	O	P	Q
DD-45	2380	2045	874	1981	2311	211	80	1270	1106	956	230	870	802	2088	214	240	244	1841	308
DD-60	2380	2045	874	1981	2311	211	80	1270	1366	956	230	870	802	2088	214	240	244	1841	308
DD-80	2380	2045	874	1981	2311	211	80	1270	1598	956	230	870	802	2088	214	240	244	1865	308