



DD-SILVER ET2

TUMBLE

DRYERS

DD-45 / 60 / 80



EASY TOUCH 2

7" touch screen user friendly and programmable ET2
USB Connection. PC software free of charge for programming, traceability, data analysis...
Videos on display (ads, instructions, etc.)
37 languages



OUTSTANDING FEATURES

Reversing drum action as standard
Stainless steel drum as standard
Frequency inverter as standard



EFFICIENCY

DOUBLE FLOW - mixed axial-radial airflow
Big fluff filter



VERSATILITY

Make to order - customisation
WET CLEANING



CONNECTIVITY

Remote technical service
Management of laundries



ERGONOMICS

Drawer as fluff filter, made of stainless steel
Biggest door diameters



MAINTENANCE

Technical menu: statistics, alarm, autotest, data recovery for technicians and maintenance



OTHERS

Grey skinplate outer casing, stainless steel look
SOFT DRY - new drum with stamped holes
COOL DOWN - anti-wrinkle at the end of the cycle
Electric, gas and steam heating
CE approved



OPTIONS

- CARE DRY - Intelligent humidity control with new drum inlet temperature control
- Double doorglass
- Reverse door opening
- SPRINKLER - Integrated Fire Extinguishing System
- New perfumes dosing/vaporizing system
- Printer
- Tropicalized model
- Danube Online IoT communication
- Stainless steel outer casing
- Stainless steel front panel
- Stainless steam battery
- Low pressure steam battery
- Fluff filter with grid 0,6 or 1,2 mm (standard is 0,3 mm)
- Rear panel with external air inlet + filter



Intertek



Intertek

TECHNICAL DATA	UNIT.	DD-45 SILVER ET2	DD-60 SILVER ET2	DD-80 SILVER ET2			
CAPACITY							
Capacity 1/18	Kg	50	67	83			
Capacity 1/20	Kg	45	60	75			
Hourly Output SILVER*	Kg/h	96-90	129-120	171-160			
Evaporation capacity SILVER*	l/h	42,50	65,80	96,50			
DRUM							
Ø Drum	mm	1.225	1.225	1.225			
Ø Door	mm	802	802	802			
Door center height	mm	1.275	1.275	1.275			
Load hole bottom height	mm	874	874	874			
Drum length	mm	760	1.020	1.252			
Drum volume	l	896	1.202	1.500			
POWER							
Drum motor power	Kw	0,75	1,1	1,5			
Fan motor power SILVER	Kw	1,1	1,1	1,1			
Electric heating power ALL RANGES	Kw	54	72	72			
Total electric power (elec.model) SILVER	Kw	55,90	74,25	74,65			
Gas heating power ALL RANGES	Kw	60	90	120			
Total electric power (gas model) SILVER	Kw	1,90	2,25	2,65			
Steam heating power ALL RANGES	Kw	91,30	128	128			
Total electric power (steam model) SILVER	Kw	1,90	2,25	2,65			
CONNECTIONS		ELECTRICAL	STEAM / GAS	ELECTRICAL	STEAM / GAS	ELECTRICAL	STEAM / GAS
Tension 230V - I + N + T	N° x mm2 / A	-	-	-	-	-	-
Tension 230V - III + T	N° x mm2 / A	-	4 x 2,5 / 20A	-	4 x 2,5 / 32A	-	4 x 2,5 / 32A
Tension 400V - III + N + T	N° x mm2 / A	5 x 35 / 100A	5 x 1,5 / 20A	5 x 50 / 125A	5 x 1,5 / 32A	5 x 50 / 125A	5 x 1,5 / 32A
Ø Gas inlet	BSP	3/4"		3/4"		3/4"	
Ø Steam inlet	BSP	1"		1"		1"	
Ø Condensed (Steam models)	BSP	1"		1"		1"	
DIMENSIONS / PACKING DIMENSIONS							
Net Width / Gross Width	mm	1.270 / 1.330		1.270 / 1.330		1.270 / 1.330	
Net Depth / Gross Depth	mm	1.106 / 1.185		1.366 / 1.445		1.598 / 1.705	
Net Height / Gross Height	mm	2.380 / 2.150		2.380 / 2.150		2.380 / 2.150	
Height without heating battery	mm	1.950		1.950		1.950	
Net weight / Gross weight	Kg	395 / 430		529 / 575		657 / 715	
OTHERS							
Max airflow SILVER	m3/h	3.000		3.000		3.000	
Ø Fume exhaust	mm	300		300		300	
Sound level SILVER	dB	67		67		67	

* It may vary depending on the type of heating, filter cleanliness or extraction type.

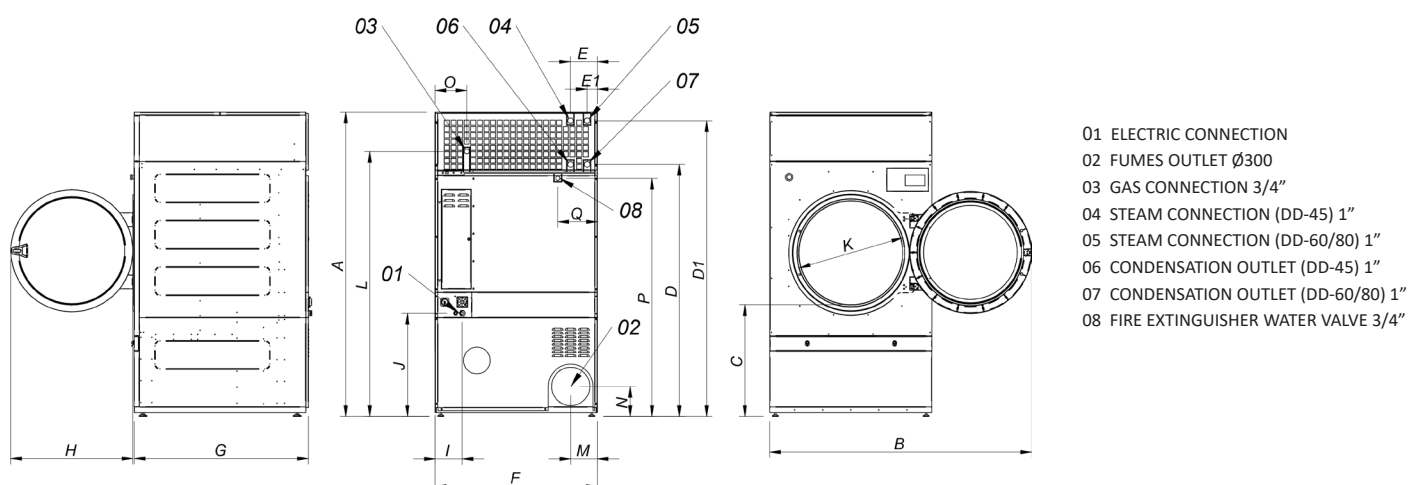

	A	B	C	D	D1	E	E1	F	G	H	I	J	K	L	M	N	O	P	Q
DD-45	2380	2045	874	1981	2311	211	80	1270	1106	956	230	870	802	2088	214	240	244	1841	308
DD-60	2380	2045	874	1981	2311	211	80	1270	1366	956	230	870	802	2088	214	240	244	1841	308
DD-80	2380	2045	874	1981	2311	211	80	1270	1598	956	230	870	802	2088	214	240	244	1841	308