



HIGH SPIN WASHER EXTRACTORS

WED-27 / 35C / 45C ET2



EASY TOUCH 2

User friendly and totally programmable 7" ET2
USB Connection. PC software free of charge for
programming, traceability, data analysis...
Videos on display (ads, instructions)
37 languages
8 dosing signals as standard



G FACTOR

High G-factor 450
Reduced residual moisture, reduced drying time



EFFICIENCY

Intelligent consumption
Optimal loading
Water Recovery tanks ready: AQUABAC
Low water consumption



VERSATILITY

Make to order: customisation
OPL < > COIN
Electric < > Hot water
Drain valve < > Pump
WET CLEANING features as standard



CONNECTIVITY

Remote technical service
Management of laundries: OPL and COIN
Remote payment



ERGONOMICS

Biggest door diameters: Ø 460 mm (for WED-27) and
Ø 560 mm (for WED-35C/45C)
Easy opening/closing system for door lock



MAINTENANCE

Hinged panel: easy access to parts
Equivalent parts for all models: contactors,
electronic devices, gear
Technical menu: traceability, error diagnosis



OTHERS

Free standing models
Grey skinplate outer casing
Drum and tub in stainless steel AISI 304
Detergent dispenser with 4 compartments
Electronic control of imbalance with frequency control
LOADING AID feature: water and rotation control
CE and WRAS approved product. Option ETL



OPTIONS

- Double drain
- Normally closed valve
- AQUA FLOW: recirculation of bath water
- Levelling feet
- 6 extra dosing signals relay card
- Weighing system: automatic weighing sensor system on feet (Includes kit with 6 extra dosing signals)
- Printer
- Danube Online IoT communication
- Silicon gasket (for WED-27)
- Reversible door opening
- Tropicalized model: protected board
- Steam kit to transform an E or HW heated machine into steam version
- Plinth to level all machines from top
- Plinth to align loading height (door base at 850 mm)
- Stainless steel AISI 304 outer casing
- Stainless steel AISI 304 front panel
- Coin/token kits
- Delayed door opening in case of power outage



Intertek



Intertek

TECHNICAL DATA	UNIT.	WED-27 ET2	WED-35C ET2	WED-45C ET2			
DRUM							
Load capacity 1:9 / 1:10	Kg	28/25	39/35	47/42			
Volume	l	250	350	420			
Diameter	mm	770	860	860			
Depth	mm	530	602	723			
GENERAL DETAILS							
Washing speed / Spining speed	r.p.m.	45/1.024	42,5/966	42,5/966			
G Factor	-	450	450	450			
Maximum force transmitted	KN	4,92 ±1,75	7,36 ±2,45	7,36 ±2,45			
Frequency-dynamic force	Hz	15	14,3	14,3			
Noise level	dB	<70	<70	<70			
Coin laundry version	-	YES	YES	YES			
Double drain	-	OPT	OPT	OPT			
Weighing System / Tilting System	-	OPT / NO	OPT / NO	OPT / NO			
DOOR							
Height door center / door base	mm	865/560	885/540	885/540			
Diameter	mm	460	560	560			
POWER							
Motor	kW	4	6	6			
Electric heating power	kW	18	21	21			
Total electric power (electric model)	kW	19,2	23	23			
Total electric power (hw, steam mod.)	kW	4	6	6			
CONNECTIONS							
		ELECTRIC	STEAM / HOT WATER	ELECTRIC	STEAM / HOT WATER.	ELECTRIC	STEAM / HOT WATER.
Tension 230V - I + N + T	N° x mm2 / A	-	2 x 2,5 / 20A	-	-	-	-
Tension 230V - III + T	N° x mm2 / A	3 x 16 / 63A	-	3 x 25 / 63A	3 x 1,5 / 16A	3 x 25 / 63A	3 x 1,5 / 16A
Tension 400V - III + N + T	N° x mm2 / A	4 x 4 / 32A	-	4 x 6 / 40A	4 x 1,5 / 16A	4 x 6 / 40A	4 x 1,5 / 16A
Steam inlet (Steam model)	Inch	3/4"		3/4"		3/4"	
Maximum steam consumption (Steam model)	Kg/h	15		18		18	
Water inlet	Inch	3/4"		3/4"		3/4"	
Water main pressure	Kgs/cm ²	2-4		2-4		2-4	
Maximum water consumption*	Lit/h	175,5		261,3		261,3	
Drain	Inch	3"		3"		3"	
Drainage capacity	Lit/min	200		200		200	
DIMENSIONS / PACKING DIMENSIONS							
Net Width / Gross Width	mm	979/1.040		1.095/1.165		1.095/1.165	
Net Depth / Gross Depth	mm	1.041/1.160		1.184/1.230		1.304/1.480	
Net Height / Gross Height	mm	1.553/1.850		1.598/1.920		1.598/1.920	
Net weight / Gross weight	kg	490/545		750/820		800/870	
Volume	m3	2,23		2,75		3,31	

* N°20 Program, 75% load

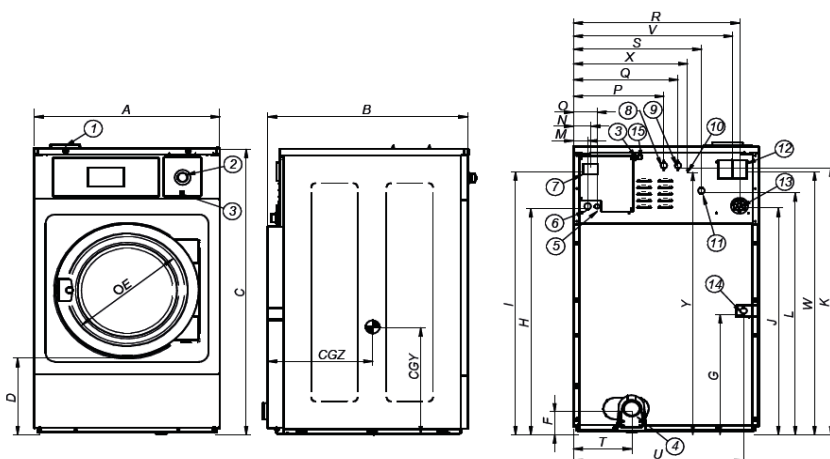

- 1 SOAP DISPENSER
- 2 EMERGENCY STOP
- 3 USB PORT
- 4 DRAIN
- 5 ELECTRIC CONNECTION TO LIQUID SOAP PUMPS
- 6 ELECTRICAL CONNECTION
- 7 MAIN SWITCH
- 8 AUXILIAR WATER INLET
- 9 HOT WATER INLET
- 10 EQUIPOTENTIAL CONNECTION
- 11 COLD WATER INLET
- 12 BLUR OUTPUT / WATER OVERLOAD
- 13 LIQUID SOAP CONNECTION
- 14 STEAM CONNECTION
- 15 ETHERNET PORT

	A	B	C	D	E	F	G	H	I	J	K	L	M	N	O	P	Q	R	S	T	U	V	W	X	Y	CGY	CGZ
WED-27	979	1.041	1.553	560	460	133	490	1.282	1.450	1.259	1.465	1.354	61	74	101	481	561	861	673	367	909	831	1.424	624	1.510	773	710
WED-35C	1.095	1.184	1.600	525	560	158	576	1.330	1.498	1.331	1.513	1.417	61	74	101	596	676	976	808	384	1.028	946	1.496	740	1.558	795	732
WED-45C	1.095	1.304	1.600	525	560	158	576	1.330	1.498	1.331	1.513	1.417	61	74	101	596	676	976	808	384	1.028	946	1.496	740	1.558	795	800