

# MED-16/22 ET2 BARRIER WASHER EXTRACTORS



## EASY TOUCH 2

7" touch screen easy to use and fully programmable ET2, display on dirty side  
Connection USB. free software online for programming, telemetry, data analysis...  
Videos on display (instructions...)  
37 languages  
8 dosing signals as standard



## OUTSTANDING FEATURES

Automatic positioning of drum  
2 water inlets  
WET CLEANING, telemetry as standard  
Dual heating (electric - steam) model available  
G FACTOR 350



## EFFICIENCY

Optimized consumption, automatic or manual adjustment of water levels and detergents according to the load  
Ready for water recovery tanks: AQUABAC  
High G factor: reduced residual moisture, reduced drying time  
Water saving: 3 configurable levels of savings



## CONNECTIVITY

**IoT - Danube Online standard**  
Remote technical service  
Laundry management



## ERGONOMICS

Huge loading and unloading doors opening  
Easy drum opening by push button  
Loading height (670 mm from door base)



## MAINTENANCE

Electric elements on left side, mechanical ones on right side, connections on the top (protected from detergents and water splashes)  
Central drain as standard  
Technical menu : statistics, alarms, autotest, data recovery for technicians and maintenance



## OTHERS

2 opposed doors  
Grey skinplate outer casing.  
Stainless steel AISI 304 top panel, vat and drum  
Electronic control of imbalance with frequency inverter  
Electric, steam or dual heating  
CE approved



## OPTIONS

- Second 7" screen on clean side
- Automatic weighing system on feet
- 6 extra dosing signals
- Printer
- Third water inlet
- Double drain
- Titration valve
- Side drain valve
- Low steam pressure
- 4 compartments detergent box kit
- Drum motor brake
- UPS protection kit in case of power failure (only with brake option)
- End of cycle light alarm
- 1-door opening (single side operation)
- Plinth for loading height at 850 mm (door base)
- Stainless steel AISI 304 outer casing
- Stainless steel sanitary frame
- Other tensions

TECHNICAL DATA	UNIT.	MED-16 ET2	MED-22 ET2		
<b>DRUM</b>					
Capacity 1:9 / 1:10	Kg	18 / 16	24 / 22		
Volume	l	158	220		
Diameter	mm	633	633		
Depth	mm	500	700		
No of drum compartment	No	1	1		
Pullman partition of drum		N/A	N/A		
<b>GENERAL DETAILS</b>					
Washing / spin speed	r.p.m.	45 / 1000	45 / 1000		
G Factor	-	350	350		
Dynamic force	KN	5,5 ±1,12	6,25 ±1,54		
Dynamic force frequency	Hz	15,4	15,4		
Sound level	dB	<70	<70		
Double drain	-	OPT	OPT		
Weighing system	-	OPT	OPT		
<b>DRUM</b>					
Height door bottom	mm	670	670		
Drum opening dimensions	mm	400 x 315	400 x 315		
Vat opening dimensions	mm	455 x 415	455 x 415		
<b>POWER</b>					
Motor	kW	2,2	2,2		
Electric heating	kW	12	18		
Total electric power (elec mod)	kW	14,2	20,2		
Total electric power (steam mod)	kW	2,2	2,2		
<b>CONNECTIONS</b>		<b>ELECTRIC / DUAL</b>	<b>STEAM</b>	<b>ELECTRIC / DUAL</b>	<b>STEAM</b>
Tension 230V - I + N + T	Nº x mm2 / A	-	3 x 1,5 / 6A	-	3 x 1,5 / 6A
Tension 230V - III + T	Nº x mm2 / A	4 x 10 / 40A	-	4 x 10 / 50A	-
Tension 400V - III + N + T	Nº x mm2 / A	5 x 6 / 25A	-	5 x 6 / 32A	-
steam inlet (steam mod)	Inch	3/4"		3/4"	
Max. steam consumption	Kg/h	9		12	
Water inlet	Inch	3/4"		3/4"	
Water pressure	Kgs/cm <sup>2</sup>	3-5		3-5	
Max. water consumption*	Lit/h	144		198	
Drain	Inch	3"		3"	
Drain flow	Lit/min	160		160	
<b>OVERALL DIMENSIONS / PACKING DIMENSIONS</b>					
Net width / Gross width	mm	1.056 / 1.072		1.245 / 1.262	
Net depth / Gross depth	mm	1.071 / 1.102		1.071 / 1.102	
Net height / Gross height	mm	1.417 / 1.530		1.417 / 1.530	
Net weight / Gross weight	kg	438 / 459		471 / 494	
Volume	m <sup>3</sup>	1,60 / 1,81		1,88 / 2,13	

\* N<sup>o</sup>2 Program, 100% load

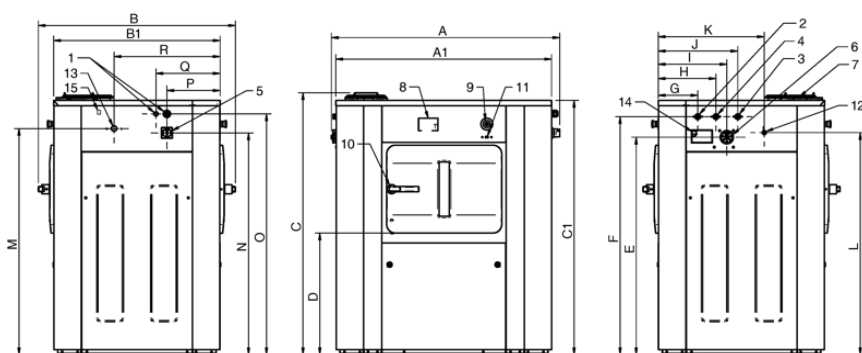

01. Electrical connexion
02. Hot water
03. Cold water
04. Soft water
05. Main switch
06. Liquid products inlet
07. Detergent box (option)
08. Control panel
09. Emergency stop
10. Door opening
11. USB port
12. Dosing pumps connexion
13. Steam inlet
14. Exhaust
15. Ethernet port

	A	B	C	A1	B1	C1	D	E	F	G	H	I	J	K	L	M	N	O	P	Q	R
MED-16	1.054	1.082	1.426	984	914	1.385	661	1.184	1.296	217	317	377	437	582	1.209	1.231	1.207	1.311	292	352	582
MED-22	1.254	1.082	1.426	1.184	914	1.385	661	1.184	1.296	217	317	377	437	582	1.209	1.231	1.207	1.311	292	352	582

