



## EASY TOUCH 2

User friendly and totally programmable 7" ET2 USB Connection. Online platform free of charge for programming, telemetry, data analysis  
Videos on display (ads, instructions, etc.)  
37 languages



## OUTSTANDING FEATURES

Reversing drum action as standard  
Stainless steel drum as standard  
Frequency inverter as standard



## EFFICIENCY

CARE DRY - Intelligent humidity control with new drum inlet temperature control.  
AIR RE-CYCLE - Efficient air recirculation system  
INSULATED PANELS - Complete air-flow circuit  
Double door glass  
OPTIMAL FLOW - New optimized system of mixed airflow  
Big fluff filter



## VERSATILITY

Make to order - customisation  
WET CLEANING  
OPL > SELF models easily transformable in self version



## CONNECTIVITY

**Danube Online communication - IoT standard**  
Remote technical service  
Management of laundries



## ERGONOMICS

Drawer as fluff filter, stainless steel mesh  
Biggest door diameters  
Opening sense of door adjustable on site



## MAINTENANCE

Hinged control panel: easy and ergonomic access  
Technical menu: statistics for technicians and maintenance with external console (option)



## OTHERS

Grey skinplate outer casing, stainless steel look  
Transmission by direct drive  
SPRINKLER - Integrated Fire Extinguishing System  
SOFT DRY - new drum with stamped holes  
COOL DOWN - anti-wrinkle at the end of the cycle  
Electric, gas and steam heating  
CE approved



## OPTIONS

- Opposite door opening
- Tropicalized model
- Perfume dosing / spraying system
- Back panel external air + filter
- Fluff filter with grid 0,6mm (standard is 0,3mm)
- Fluff filter with grid 1,2mm (standard is 0,3mm)
- Stainless steel front and side panels
- Front panel in stainless steel
- Steam battery in stainless steel
- Low pressure steam battery
- Reduced power (12kw instead of 18kw) for DD-14
- Ship voltage for electric models:  
440V III 50/60 Hz No neutral
- Other voltages available
- Maritime wooden packing

TECHNICAL DATA	UNIT.	DD-11 GOLD ET2		DD-14 GOLD ET2	
<b>CAPACITY</b>					
Capacity 1/18 // Capacity 1/20	Kg	11,7 // 10,5		15 // 13,5	
Hourly Output (electr. // gas)	Kg/h	21,7 // 31,3		29 // 32,5	
Evaporation capacity (electr. // gas)	l/h	11 // 15		14,5 // 15,6	
<b>DRUM</b>					
Ø Drum	mm	750		750	
Ø Door	mm	574		574	
Door center height	mm	976		976	
Door base height	mm	689		689	
Drum length	mm	475		610	
Drum volume	l	210		269	
<b>POWER</b>					
Drum motor power	kW	0,37		0,37	
Fan motor power	kW	0,55		0,55	
Electric heating power	kW	12		18	
Total electric power (elec.model)	kW	12,97		18,97	
Gas heating power	kW	20,51		20,51	
Instant propane gas consumption (G31)	kg/h	1,76		1,76	
Instant natural gas consumption (G20)	m3/h	2,17		2,17	
Total electric power (gas model)	kW	0,97		0,97	
Steam heating power	kW	30		30	
Total electric power (steam model)	kW	0,97		0,97	
<b>CONNECTIONS</b>					
		<b>ELECTRICAL</b>	<b>GAS/STEAM</b>	<b>ELECTRICAL</b>	<b>GAS/STEAM</b>
Tension 230V - I + N + T	N° x mm2 / A	3 x 25 / 63A	3 x 1,5 / 20A	-	3 x 1,5 / 20A
Tension 230V - III + T	N° x mm2 / A	4 x 10 / 40A	3 x 1,5 / 20A	4 x 16 / 63A	3 x 1,5 / 20A
Tension 400V - III + N + T	N° x mm2 / A	5 x 4 / 25A	3 x 1,5 / 20A	5 x 10 / 32A	3 x 1,5 / 20A
Ø Gas inlet	BSP	1/2"		1/2"	
<b>DIMENSIONS / PACKING DIMENSIONS</b>					
Net width / Gross width	mm	785 / 865		785 / 865	
Net Depth / Gross Depth	mm	855 / 940		989 / 1074	
Net Height / Gross Height	mm	1694 / 1840		1694 / 1840	
Net weight / Gross weight	Kg	172 / 180		180 / 190	
<b>OTHERS</b>					
Max airflow	m3/h	1200		1.200	
Ø Fume exhaust	mm	200		200	
Sound level	dB	64		64	

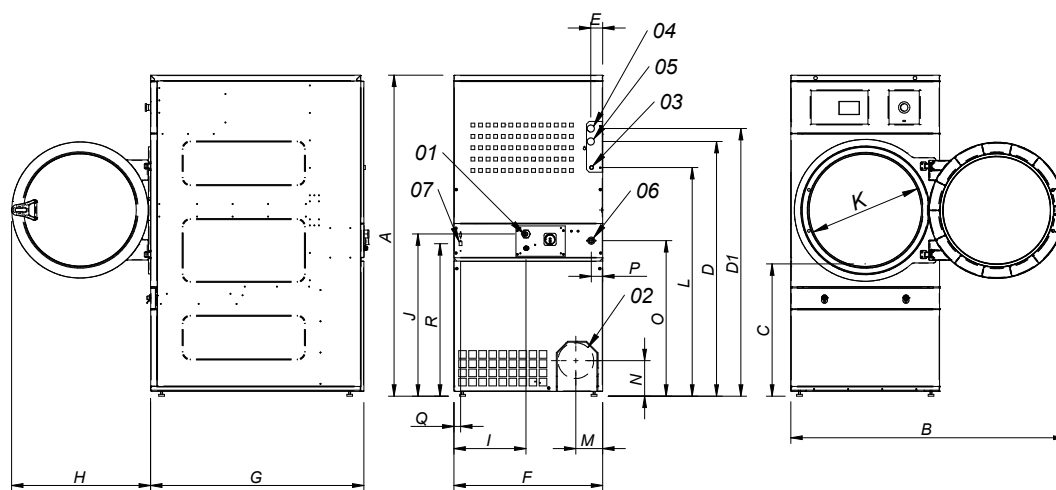

- 01 POWER SUPPLY
- 02 FUMES OUTPUT Ø200
- 03 GAS INLET 1/2"
- 04 STEAM INLET 3/4"
- 05 CONDENSATE OUTLET 3/4"
- 06 SPRINKLER VALVE 3/4"
- 07 ETHERNET CONNECTION

	A	B	C	D	D1	E	E1	F	G	H	I	J	K	L	M	N	O	P	Q	R
DD-11	1694*	1447	689	1354	1422	68	68	785	855	735	380	870	575	1226	133	180	830	65	35	805
DD-14	1694*	1447	689	1354	1422	68	68	785	989	735	380	870	575	1226	133	180	830	65	35	805

\* Measurement with legs mounted (30mm)

