

DD- 18 / 22 BASIC EM TUMBLE DRYERS



EM PROGRAMMER

Easy-to-use electronic control with push buttons to control temperature and time



OUTSTANDING FEATURES

Reversing drum action as standard
Galvanized drum as standard
Frequency inverter as standard



EFFICIENCY

Big fluff filter



VERSATILITY

Make to order - customisation
OPL > Multivending - Standard OPL model easily transformable to coin laundry uses



ERGONOMICS

Biggest door diameters
Opening sense of door adjustable on site



MAINTENANCE

Hinged control panel: easy and ergonomic access
Technical menu: statistics for technicians and maintenance with external console (with console option)
Easy to access to components



OTHERS

White painted panels
Transmission by direct drive
COOL DOWN - anti-wrinkle at the end of the cycle
Electric or gas heating
CE approved



OPTIONS

- EM programmer display



- Opposite door opening
- Back panel external air + filter
- Reduced power (12kw instead of 18kw) for electric heated DD-18 model
- Ship voltage for electric models: 440V III 50/60 Hz No neutral
- Other voltages available



Fluff filter

TECHNICAL DATA	UNIT.	DD-18-BASIC EM		DD-22-BASIC EM	
CAPACITY					
Capacity 1/18	Kg	18,3		24,3	
Capacity 1/20	Kg	16,5		21,9	
Hourly Output (electr. // gas)	Kg/h	28,3 // 31,9		34 // 40	
Evaporation capacity (electr. // gas)	l/h	14,10 // 16,30		17 // 20	
DRUM					
Ø Drum	mm	750		835	
Ø Door	mm	574		574	
Door center height	mm	976		1030	
Door base height	mm	689		743	
Drum length	mm	746		800	
Drum volume	l	330		438	
POWER					
Drum motor power	kW	0,37		0,37	
Fan motor power	kW	0,25		0,55	
Electric heating power	kW	18		24	
Total electric power (elec.model)	kW	18,67		24,97	
Gas heating power	kW	20,51		31	
Instant propane gas consumption (G31)	kg/h	1,76		2,66	
Instant natural gas consumption (G20)	m3/h	2,17		3,28	
Total electric power (gas model)	kW	0,67		0,97	
Steam heating power	kW	30		49,2	
Total electric power (steam model)	kW	0,67		0,97	
CONNECTIONS					
		ELECTRICAL		GAS/STEAM	
Tension 230V - I + N + T	Nº x mm2 / A	-		3 x 1,5 / 20A	
Tension 230V - III + T	Nº x mm2 / A	4 x 16 / 63A		3 x 1,5 / 20A	
Tension 400V - III + N + T	Nº x mm2 / A	5 x 10 / 32A		3 x 1,5 / 20A	
Ø Gas inlet	BSP	1/2"		1/2"	
DIMENSIONS / PACKING DIMENSIONS					
Net width / Gross width	mm	785 / 865		890 / 970	
Net Depth / Gross Depth	mm	1125 / 1210		1255 / 1345	
Net Height / Gross Height	mm	1694 / 1840		1812 / 1940	
Net weight / Gross weight	Kg	187 / 200		210 / 230	
OTHERS					
Max airflow	m3/h	850		1.200	
Ø Fume exhaust	mm	200		200	
Sound level	dB	64		65	

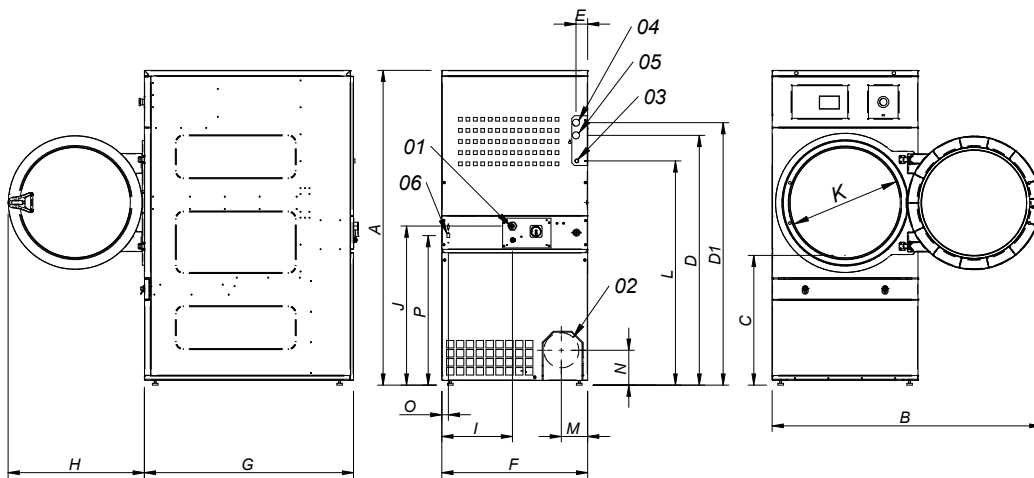

- 01 POWER SUPPLY
- 02 FUMES OUTPUT Ø200
- 03 GAS INLET 1/2"
- 04 STEAM INLET 3/4" (DD-18)
- 04 STEAM INLET 1" (DD-22)
- 05 CONDENSATE OUTLET 3/4" (DD-18)
- 05 CONDENSATE OUTLET 1" (DD-22)
- 06 ETHERNET CONNECTION (only available CONTROL ET2 models)

	A	B	C	D	D1	E	E1	F	G	H	I	J	K	L	M	N	O	P
DD-18	1694*	1447	689	1354	1422	68	68	785	1125	735	380	870	575	1226	133	180	35	805
DD-22	1812*	1552	743	1430	1532	112	55	890	1255	735	107	920	575	1344	238	180	37	860

* Measurement with legs mounted (30mm)

